

Dealer's Manual

ROAD	MTB	Trekking
City Touring/ Comfort Bike	URBAN SPORT	E-BIKE

NEXUS

INTER-5E



- SG-C7000-5
- SL-C7000-5
- CS-C7000
- SM-C7000-5

CONTENTS

MODELS COVERED BY THIS DEALER'S MANUAL.....	3
IMPORTANT NOTICE.....	4
TO ENSURE SAFETY.....	5
LIST OF TOOLS TO BE USED.....	11
INSTALLATION	13
Installation of the sprocket to the hub.....	13
Installation of the cassette joint to the hub	14
Installing the INTER M brake to the hub body.....	16
Installation of the hub to the frame.....	16
Installation of the disc brake rotor	20
Installation of the shifting cable	21
Installing to the cassette joint.....	22
ADJUSTMENT	29
Adjusting the cassette joint.....	29
MAINTENANCE	33
Disconnecting the shifting cable when removing the rear wheel from the frame	33
Replacing the inner cable.....	34
Oil maintenance of the internal assembly.....	36

MODELS COVERED BY THIS DEALER'S MANUAL

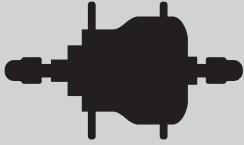
This Dealer's Manual is for the following models.

Part/Series		INTER-5E
Internal geared hub 	Coaster brake + Disc brake	-
	Disc brake	SG-C7000-5D
	Coaster brake	SG-C7000-5C
	INTER M brake	SG-C7000-5R
	V-BRAKE	SG-C7000-5V
Shifting lever 	REVOSHIFT lever	SL-C7000-5

IMPORTANT NOTICE

- **This dealer's manual is intended primarily for use by professional bicycle mechanics.**

Users who are not professionally trained for bicycle assembly should not attempt to install the components themselves using the dealer's manuals. If any part of the information on the manual is unclear to you, do not proceed with the installation. Instead, contact your place of purchase or a local bicycle dealer for their assistance.

- Make sure to read all instruction manuals included with the product.
- Do not disassemble or modify the product other than as stated in the information contained in this dealer's manual.
- All manuals and technical documents are accessible online at <https://si.shimano.com>.
- For consumers who do not have easy access to the internet, please contact a SHIMANO distributor or any of the SHIMANO offices to obtain a hardcopy of the User's Manual.
- Please observe the appropriate rules and regulations of the country, state or region in which you conduct your business as a dealer.

For safety, be sure to read this dealer's manual thoroughly before use, and follow it for correct use.

The following instructions must be observed at all times in order to prevent personal injury and physical damage to equipment and surroundings. The instructions are classified according to the degree of danger or damage which may occur if the product is used incorrectly.

 **DANGER**

Failure to follow the instructions will result in death or serious injury.

 **WARNING**

Failure to follow the instructions could result in death or serious injury.

 **CAUTION**

Failure to follow the instructions could cause personal injury or physical damage to equipment and surroundings.

TO ENSURE SAFETY

WARNING

- **Be sure to follow the instructions provided in the manuals when installing the product.**

It is recommended to use genuine SHIMANO parts only. If parts such as bolts and nuts become loose or damaged, the bicycle may suddenly fall over, which may cause serious injury.

In addition, if adjustments are not carried out correctly, problems may occur, and the bicycle may suddenly fall over, which may cause serious injury.

-  Be sure to wear safety glasses or goggles to protect your eyes while performing maintenance tasks such as replacing parts.

Be sure to also inform users of the following:

- Each bicycle may handle slightly differently depending on the model.

Therefore, be sure to learn the proper braking technique (including brake lever pressure and bicycle control characteristics) and operation of your bicycle. Improper use of your bicycle's brake system may result in a loss of control or a fall, which could lead to severe injury. For proper operation, consult a professional bicycle dealer or the bicycle's owner's manual. It is also important to practice riding and braking, etc.

For Installation to the Bicycle, and Maintenance:

- When securing the brake arm to the frame, be sure to use a brake arm clip that matches the size of the chainstay, and securely tighten them with the clip bolt and clip nut to the specified tightening torque.
Use a lock nut with a nylon insert (self-locking nut) as the clip nut. It is recommended that Shimano made clip bolts, clip nuts, and arm clips be used. If the clip nut comes off the brake arm, or if the clip bolt or arm clip becomes damaged, the brake arm may rotate on the chainstay and cause the handlebars to jerk suddenly, or the bicycle wheel may lock and the bicycle may fall over, causing serious injury.
- When installing the hub to the frame, be sure to install the correct non-turn washers to the left and right sides, and securely tighten the hub nuts to the specified torques. If the non-turn washers are installed on one side only, or if the hub nuts are not tightened sufficiently, the non-turn washer may fall out, which could cause the hub axle to rotate and the cassette joint to turn, resulting in the handlebars being accidentally pulled by the shifting cable and an extremely serious accident.

■ **Disc brake rotor**

- Please make sure to keep your fingers away from the rotating disc brake rotor. The disc brake rotor is sharp enough to inflict severe injury to your fingers if caught in the openings of the disc brake rotor while it is moving.



- The calipers and disc brake rotor will become hot when the brakes are operated; do not touch them while riding or immediately after dismounting from the bicycle. Otherwise you may get burned.
- Be careful not to allow any oil or grease to get onto the disc brake rotor and brake pads. Otherwise the brakes may not work correctly.
- If any oil or grease gets on the brake pads, consult a dealer or an agency. Otherwise the brakes may not work correctly.
- If noise occurs during brake operation, the brake pads may have been worn down to the usable limit. After checking that the temperature of the brake system has cooled down sufficiently, check that the thickness of each pad is 0.5 mm or more. Or, consult a dealer or an agency.

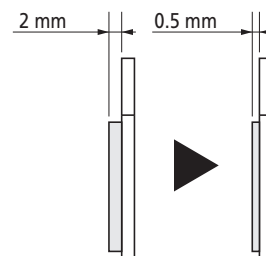

- If the disc brake rotor is cracked or deformed, immediately stop using the brakes and consult a dealer or an agency.
- If the disc brake rotor becomes worn down to a thickness of 1.5 mm or less, or if the aluminum surface appears, immediately stop using the brakes and consult a dealer or an agency. The disc brake rotor may break, and you may fall off the bicycle.

■ **Coaster brake**

- The coaster brake will become hot when the brakes are operated, so do not touch them while riding or immediately after dismounting from the bicycle. Otherwise you may get burned.

■ **Coaster brake hub**

- When using a reversed dropout, use a chain adjuster to remove excess slack from the chain.

CAUTION

Be sure to also inform users of the following:

- Be sure to shift the shifting lever one gear at a time. During shifting, reduce the force being applied to the pedals. If you try to force operation of the shifting lever or perform multi-shifting while the pedals are being turned strongly, your feet may come off the pedals and the bicycle may fall over, which could result in serious injury.
Using the shifting lever to multi-shift to a light gear may also cause the outer casing to spring out of the shifting lever.
This does not affect the capabilities of the shifting lever because the outer casing returns to the original position after shifting.

Disc brake specifications

- Disc brakes have a burn-in period, and braking force will gradually increase as the burn-in period progresses; therefore, make sure that you are aware of any such increases in braking force when using the brakes during this period. The same thing will happen when the brake pads or disc brake rotor are replaced.

Coaster brake specifications

- Continuous application of the brakes when riding down long slopes will cause the internal brake parts to become very hot, weakening braking performance, and may also cause a reduction in the amount of brake grease inside the brake, leading to problems such as abnormally sudden braking.
- Spin the wheel and confirm that the braking force of the coaster brake is correct.

Roller brake specifications

- If the brake is used frequently, the area around the brake may become hot. Do not touch the area around the brake for at least 30 minutes after riding the bicycle.

Area around the brake

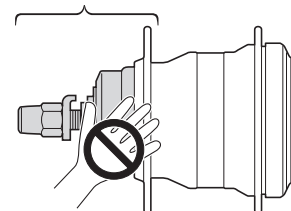

- Continuous application of the brakes when riding down long slopes will cause the internal brake parts to become very hot, weakening braking performance, as well as causing a reduction in the amount of brake grease inside the brake, which can lead to problems such as abnormally sudden braking.
- The brake unit and front hub unit should never be disassembled. If they are disassembled, they will no longer work properly.

NOTICE

Be sure to also inform users of the following:

- The gears can be shifted while lightly pedaling, but on rare occasions the pawls and ratchet inside the hub may produce some noise afterwards as part of normal gear shifting operation. In addition, a loud sound may be temporarily emitted if the gears are shifted while strongly pedaling with E-BIKE, etc., but this is normal.
- The internal geared hub is not completely waterproof. Avoid using the hub in places where water might get inside and do not use high-pressure water to clean the hub, otherwise the internal mechanism may rust.
- Do not disassemble the hub. If you need to disassemble it, contact the place of purchase.
- All of the following occurrences are due to the internal gear-shifting structure and are not the failure of the internal components.

Phenomenon	Type of hub		Gear positions where phenomenon might occur
	For coaster brakes	For roller brakes/ V-BRAKE	
Noise occurs when the pedals rotate.	x	-	All gear positions except 1st
Noise occurs when the bicycle is pushed backward.	x	x	All gear positions except 1st
The hub has a built-in mechanism that supports gear shifting and when the mechanism operates during gear shifting, noise and vibrations occur.	x	x	All gear positions
Depending on gear position, gear-shifting may feel different.	x	x	All gear positions
Noise occurs when pedal rotation is stopped during riding.	x	-	All gear positions

- Products are not guaranteed against natural wear and deterioration from normal use and aging.

- For maximum performance we highly recommend Shimano lubricants and maintenance products.

Coaster brake specifications

- If the wheels are not rotating smoothly, you need to replace or grease the brake shoes. Consult the dealer where you made the purchase.

For Installation to the Bicycle, and Maintenance:

- To maintain the product in good working order, it is recommended to have the place of purchase or a distributor carry out maintenance such as lubrication of the internal parts about once a year from the first time of use (once every 2,000 km if the bicycle is used very frequently). If the bicycle is used under harsh conditions, more frequent maintenance is required. Also, for carrying out maintenance, the use of SHIMANO internal geared hub grease or a lubrication kit is recommended. If SHIMANO grease or a SHIMANO lubrication kit is not used, problems such as a malfunction in gear shifting may occur.
- If the wheel becomes stiff and difficult to turn, lubricate it with grease.
- The gears should be periodically washed with a neutral detergent. In addition, cleaning the chain with neutral detergent and lubricating it can be an effective way of extending the life of the gears and the chain.
- If the chain keeps coming off the gears during use, replace the gears and chain.

Internal geared hub specifications

- It is recommended that the front chainring have a tire size of 28 inches or shorter and be set so that the gear ratio is about 1.4 as shown in the table below.

Chainring	CS-C7000
34	24
38	27
42	30

- For information on gear ratios that can be used, refer to the table below.

Diameter of wheel		24 inch			26 inch			27 inch		
CS-C7000 (number of teeth)		30	27	24	30	27	24	30	27	24
Chainring (number of teeth)	30	-	-	-	-	-	-	-	-	-
	31	-	-	1.29	-	-	1.29	-	-	1.29
	32	-	-	1.33	-	-	1.33	-	-	1.33
	33	-	-	1.38	-	-	1.38	-	-	1.38
	34	-	-	1.42	-	-	1.42	-	-	1.42
	35	-	1.30	1.46	-	1.30	1.46	-	1.30	1.46
	36	-	1.33	1.50	-	1.33	1.50	-	1.33	1.50*
	37	-	1.37	1.54	-	1.37	1.54*	-	1.37	1.54*
	38	1.27	1.41	1.58	1.27	1.41	1.58*	1.27	1.41	-
	39	1.30	1.44	1.63	1.30	1.44	-	1.30	1.44	-
	40	1.33	1.48	1.67*	1.33	1.48	-	1.33	1.48*	-
	41	1.37	1.52	1.71*	1.37	1.52	-	1.37	1.52*	-
	42	1.40	1.56	1.75*	1.40	1.56*	-	1.40	1.56*	-
	43	1.43	1.59	-	1.43	1.59*	-	1.43	-	-
	44	1.47	1.63	-	1.47	-	-	1.47	-	-
	45	1.50	1.67*	-	1.50	-	-	1.50*	-	-

Diameter of wheel		700C			28 inch		
CS-C7000 (number of teeth)		30	27	24	30	27	24
Chainring (number of teeth)	30	-	-	-	-	-	-
	31	-	-	1.29	-	-	1.29
	32	-	-	1.33	-	-	1.33
	33	-	-	1.38	-	-	1.38
	34	-	-	1.42	-	-	1.42
	35	-	1.30	1.46*	-	1.30	1.46*
	36	-	1.33	1.50*	-	1.33	1.50*
	37	-	1.37	-	-	1.37	-
	38	1.27	1.41	-	1.27	1.41	-
	39	1.30	1.44*	-	1.30	1.44*	-
	40	1.33	1.48*	-	1.33	1.48*	-
	41	1.37	1.52*	-	1.37	-	-
	42	1.40	-	-	1.40	-	-
	43	1.43	-	-	1.43*	-	-
	44	1.47*	-	-	1.47*	-	-
	45	1.50*	-	-	1.50*	-	-

* Can be used except for with coaster brake specifications.

-: Cannot be used

Coaster brake specifications







- Use a wheel with 3x or 4x spoke lacing. Wheels with radial lacing cannot be used. Otherwise, the spokes or the wheel may get damaged, or noise may occur when braking.
- If the wheel becomes stiff and difficult to turn, you should replace the brake shoes or lubricate with grease.
- Use only the specified grease for the brake shoes and when using a lubrication kit, remove the brake shoes to avoid contact with the oil.

The actual product may differ from the illustration because this manual is intended mainly to explain the procedures for using the product.

LIST OF TOOLS TO BE USED

LIST OF TOOLS TO BE USED

The following tools are needed for installation, adjustment, and maintenance purposes.

Tool		Tool		Tool	
	3 mm hexagon wrench		Screwdriver[#1]		TL-S700-B
	10 mm spanner		TL-LR10		Adjustable wrench

INSTALLATION

INSTALLATION

■ Installation of the sprocket to the hub

Install right-hand dust cap C to the driver in the orientation shown in the illustration.

Next, install the sprocket and secure it in place with the snap ring.

Specifications	Applicable sprockets	
	Outward assembling	Inward assembling
INTER-5E	24T, 27T, 30T	24T, 27T, 30T

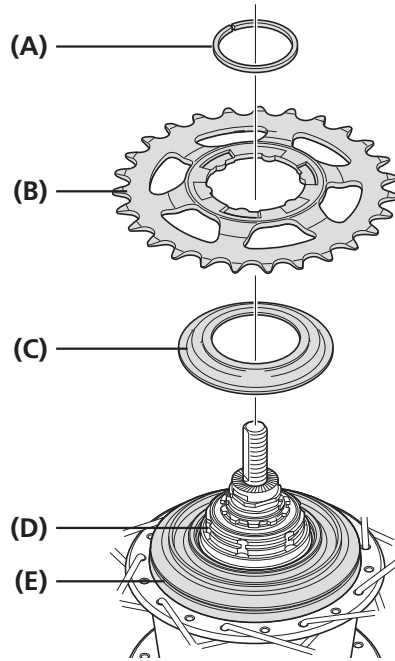

- (A)** Snap ring
- (B)** Sprocket
- (C)** Right-hand dust cap C
- (D)** Driver
- (E)** Right-hand dust cap A

■ Installation of the cassette joint to the hub

1

Install the driver cap to the driver as shown in the illustration. Note the orientation of the driver cap.

(z) Driver side

(A) Driver cap
(B) Driver
(C) Sprocket
(D) Snap ring

2

Turn the cassette joint pulley in the direction of the arrow to align the red ● marks on the pulley and the bracket.

(z) Should be aligned

(A) Pulley
(B) Bracket

3

Install it with the red ● marks (z) on the cassette joint aligned with the red ● marks (z) on the right side of the hub body.

(A) Cassette joint

INSTALLATION

▶▶ Installation of the cassette joint to the hub

4

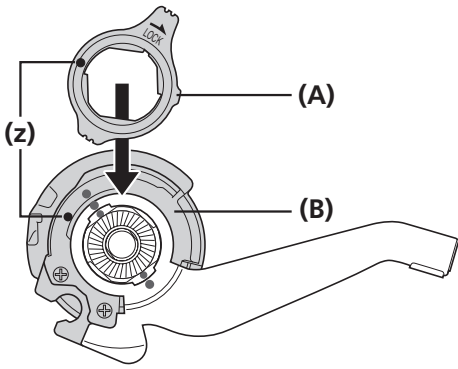

Secure the cassette joint to the hub with the cassette joint mounting ring.

When installing the cassette joint mounting ring, align the yellow ● mark (z) with the yellow ● mark (z) on the pulley of the cassette joint.

(A) Cassette joint mounting ring

(B) Pulley

5

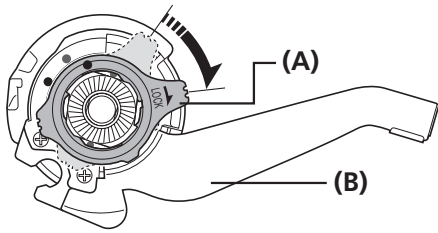

Turn the cassette joint mounting ring 45° clockwise.

Hold down the bracket securely when performing work.

(A) Cassette joint mounting ring

(B) Bracket

INSTALLATION

▶▶ Installing the INTER M brake to the hub body

■ Installing the INTER M brake to the hub body

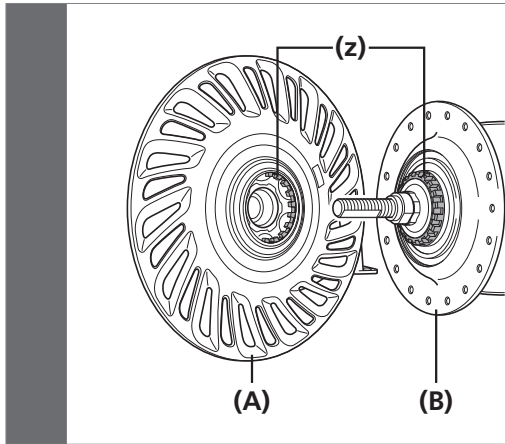

Engage the serrations (z) on the hub body with the serrations (z) on the INTER M brake, and then provisionally tighten the brake unit fixing nut.

(A) INTER M brake
(B) Hub body

■ Installation of the hub to the frame

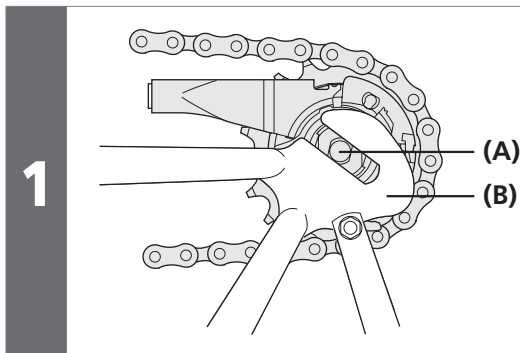

Mount the chain on the sprocket, and then set the hub axle into the dropout.

(A) Hub axle
(B) Dropout

INSTALLATION

Installation of the hub to the frame

Place non-turn washers and onto the right and left sides of the hub axle.

At this time, turn the cassette joint so that the protrusions of the non-turn washers fit into the grooves in the dropouts and align the joint to be almost parallel to the chainstay.

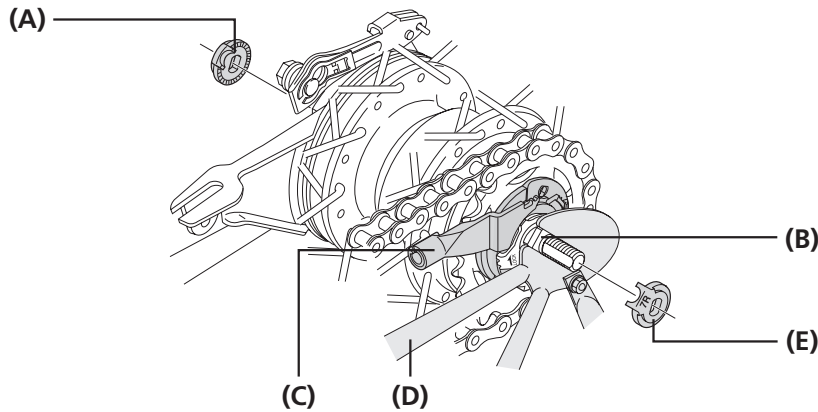

- (A) Non-turn washer (for left-side use)
- (B) Groove in dropout
- (C) Cassette joint
- (D) Chainstay
- (E) Non-turn washer (for right-side use)

NOTICE

When installing parts such as a mudguard stay to the hub axle, install them in the order shown in the illustration below.

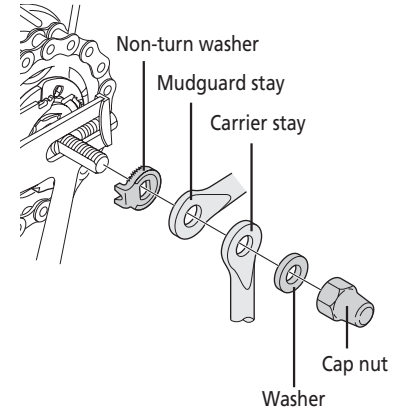

TECH TIPS

- The protrusion should be on the dropout side.
- Install the non-turn washer so that the protrusion fits securely in the dropout groove at the front and back sides of the hub axle.
- Use a non-turn washer that matches the shape of the dropout. Different non-turn washers are used for the left and right sides.

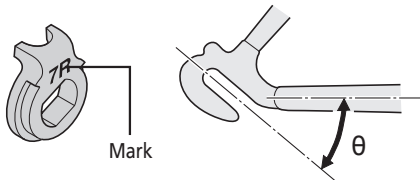

Dropout	Non-turn washer		Size
	Mark/Color		
	For right	For left	
Standard	5R/Yellow	5L/Brown	$\theta \leq 20^\circ$
	7R/Black	7L/Gray	$20^\circ \leq \theta \leq 38^\circ$
Reversed	6R/Silver	6L/White	$\theta = 0^\circ$
Reversed (Full chain case)	5R/Yellow	5L/Brown	$\theta = 0^\circ$
Vertical	8R/Blue	8L/Green	$\theta = 60^\circ - 90^\circ$

Note: Vertical type does not include the coaster specifications

In the case of INTER M brake specifications

2

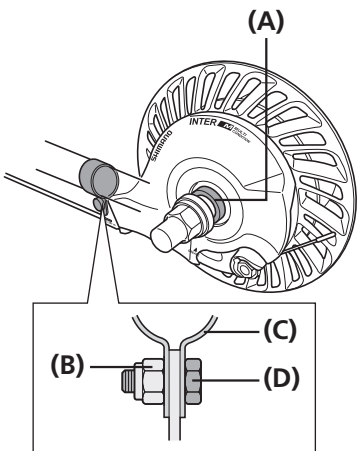

(A)

Attach the brake arm of the INTER M brake to the chainstay with the brake arm clip.

Next, temporarily fix the clip bolt and clip nut by lightly tightening them.

(B) (C) (D)

- (A) Brake fixing washer (insert manually)
- (B) Clip nut
- (C) Arm clip
- (D) Clip bolt (M6 x 16 mm)

NOTICE

Check that the brake unit is firmly secured to the hub with the brake unit fixing washer.

TECH TIPS

If the hub nuts are cap nuts, use a frame with dropouts that are at least 7 mm thick.

3

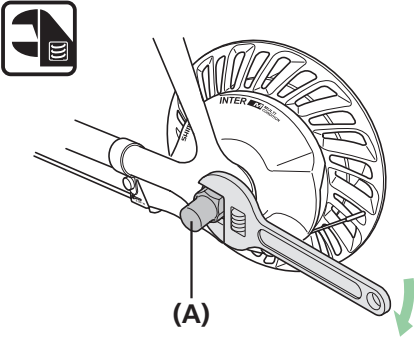

(A)

Take up slack in the chain and secure the wheel to the frame with the cap nut.

- (A) Hub nut

Tightening torque	
	30 - 45 N·m

NOTICE

Check that the wheel is fixed securely to the frame with the hub nut.

Fix the brake arm securely to the chainstay with the arm clip.

Check that the brake arm is securely fastened to the chainstay with the brake arm clip.

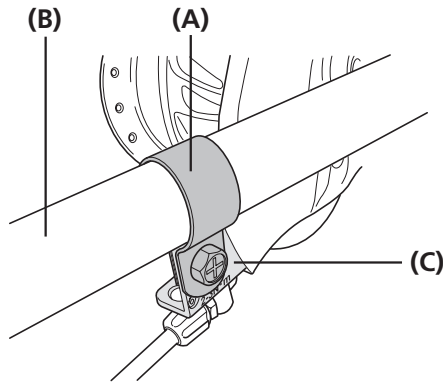

In the case of coaster brake specifications

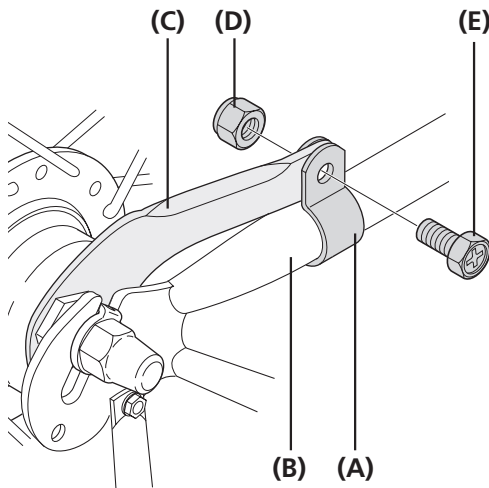

- (A) Arm clip
- (B) Chainstay
- (C) Brake arm
- (D) Clip nut
- (E) Clip bolt (M6 x 16 mm)

Tightening torque



2 - 3 N·m

WARNING

- When securing the brake arm to the frame, be sure to use a brake arm clip that matches the size of the chainstay, and securely tighten them with the clip bolt and clip nut to the specified tightening torque.
- Use a lock nut with a nylon insert (self-locking nut) as the clip nut.
- It is recommended that Shimano made clip bolts, clip nuts, and arm clips be used.
- If the clip nut comes off the brake arm, or if the clip bolt or arm clip becomes damaged, the brake arm may rotate on the chainstay and cause the handlebars to jerk suddenly, or the bicycle wheel may lock and the bicycle may fall over, causing serious injury.

NOTICE

- If it is not installed correctly, braking performance will suffer. Be careful not to apply excessive force when installing.
- If excessive force is applied to the brake arm to secure it, the wheel will make noise and become difficult to turn.
- After installing the arm clip, check that the clip bolt protrudes about 2 to 3 mm from the end face of the clip nut.

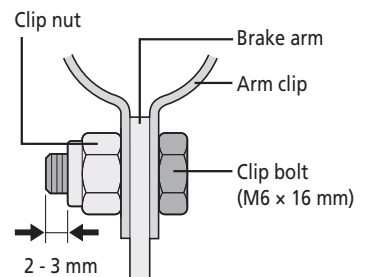



- Before using the Coaster Brake, check that the brake works properly and that the wheel turns smoothly.

■ Installation of the disc brake rotor

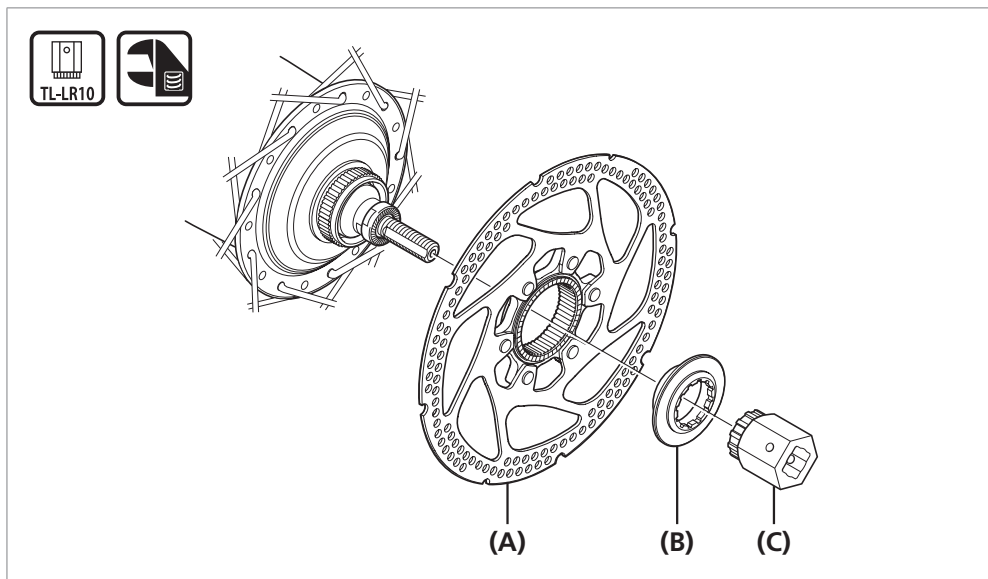
Center lock type



- (A) Disc brake rotor
- (B) Disc brake rotor fixing lock ring
- (C) TL-LR10

Tightening torque	
 	<p>40 N·m</p>

Installation of the lever

Install the lever as shown in the illustration.

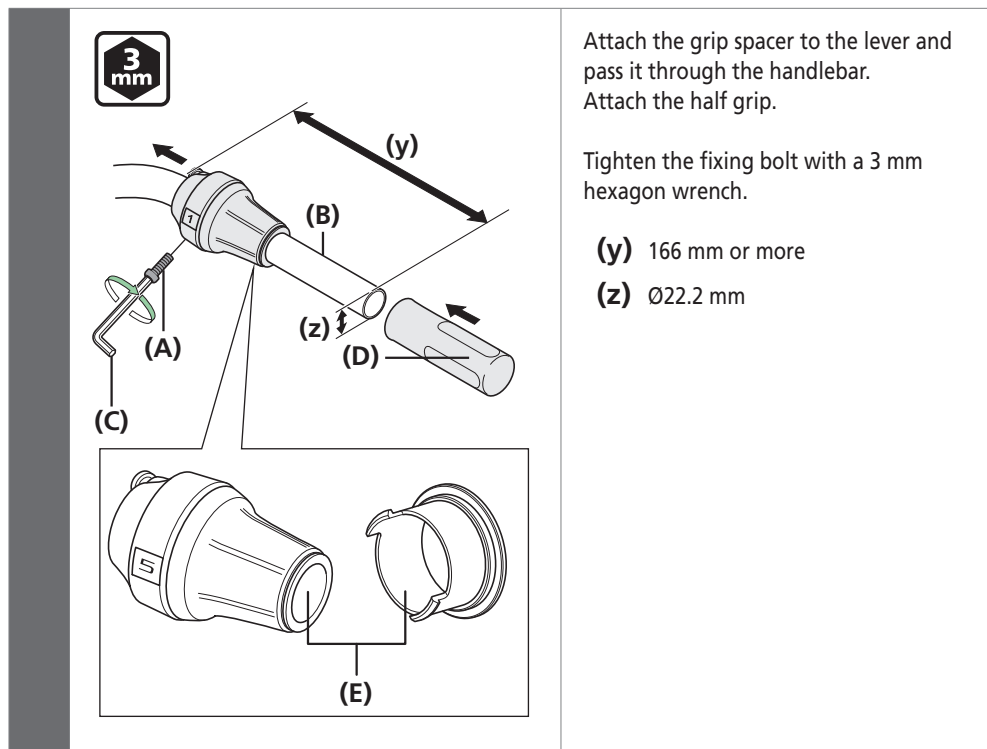

- (A) Fixing bolt
- (B) Handlebar
- (C) 3 mm hexagon wrench
- (D) Half grip
- (E) Grip spacer

Tightening torque	
	2 - 2.5 N·m

TECH TIPS

- If using Shimano half grip, the straight section of the handlebar should be 166 mm or longer. Attach the REVOSHIFT lever to this straight section.
- Leave a gap of 0.5 mm between the REVOSHIFT lever and the half grip.

■ Installation of the shifting cable

For information on how to replace the inner cable, refer to the maintenance section.

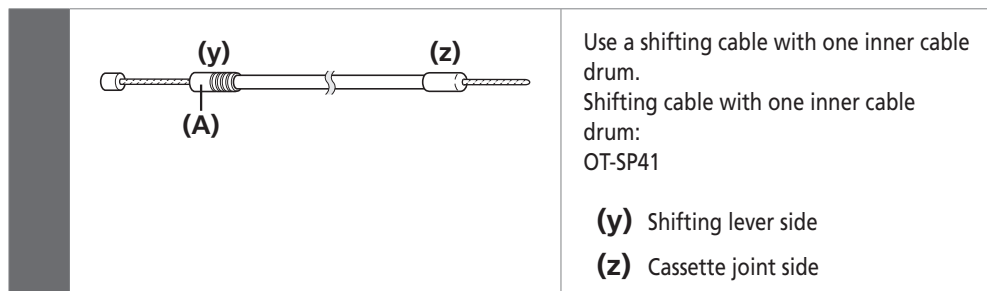

- (A) Sealed outer cap

NOTICE

Make sure that the sealed outer cap is at the shifting lever end.

■ Installing to the cassette joint

For CJ-C7000-5

1

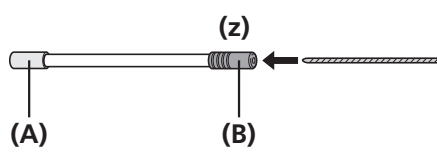

Pass the inner cable through the OT-SP41 outer casing to the end with the plastic cap.

(z) Lever side

- (A)** Aluminum cap
- (B)** Plastic cap

 **TECH TIPS**

Cutting the outer casing
If cutting the outer casing, cut it near the end with the plastic cap while the cap is still attached.

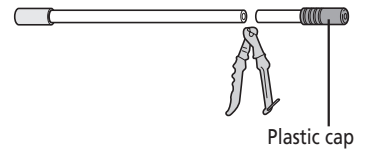

After cutting, make the cut end perfectly round and attach the plastic cap.

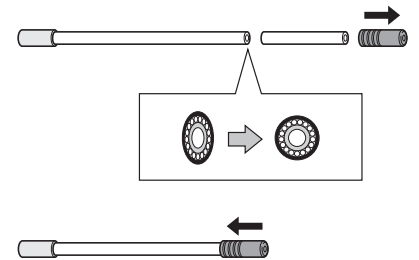

2

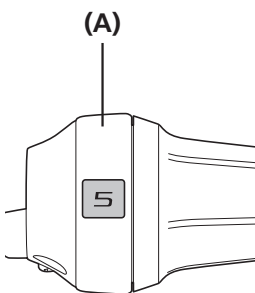

Set SL-C7000-5 to 5.

- (A)** REVOSHIFT lever

3

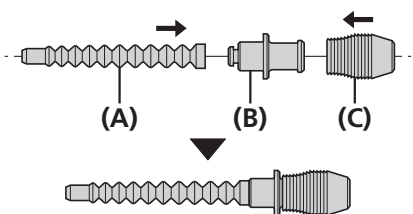

If rubber bellows and a rubber cover are attached, install the rubber cover and rubber bellows to the outer casing holder.

- (A)** Rubber bellows
- (B)** Outer casing holder
- (C)** Rubber cover

4

Wipe off any grease on the inner cable.

NOTICE

Use a new inner cable; do not use a cable which has had its end cut off.

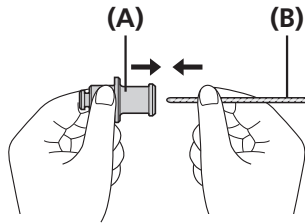

Pass the inner cable through the outer casing holder and set it.

- (A)** Outer casing holder
- (B)** Inner cable

5

Rubber bellows and rubber cover attached

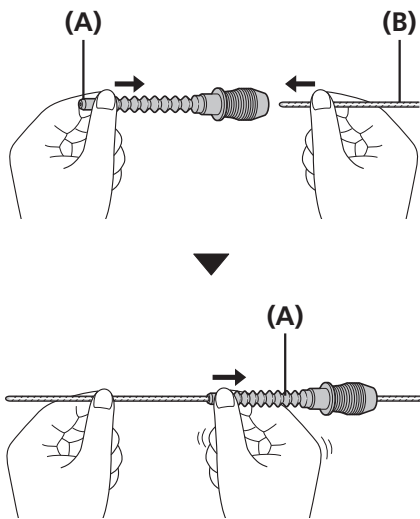

If rubber bellows and a rubber cover are attached, hold the end of the rubber bellows and insert the inner cable. Slide and set the rubber bellows.

- (A)** Rubber bellows
- (B)** Inner cable

NOTICE

Be careful not to pierce the rubber bellows with the end of the inner cable at this time.

6

Rubber bellows and rubber cover attached

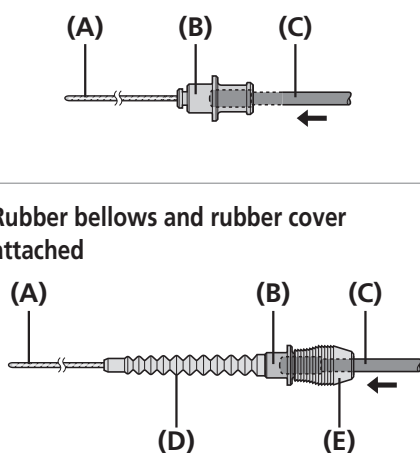

Set the outer casing to the outer casing holder. Push the outer casing so that it securely touches the holder.

- (A)** Inner cable
- (B)** Outer casing holder
- (C)** Outer casing

If rubber bellows and a rubber cover are attached, insert the outer casing into the rubber cover and set it into the outer casing holder. Push the outer casing so that it securely touches the holder.

- (A)** Inner cable
- (B)** Outer casing holder
- (C)** Outer casing
- (D)** Rubber bellows
- (E)** Rubber cover

7

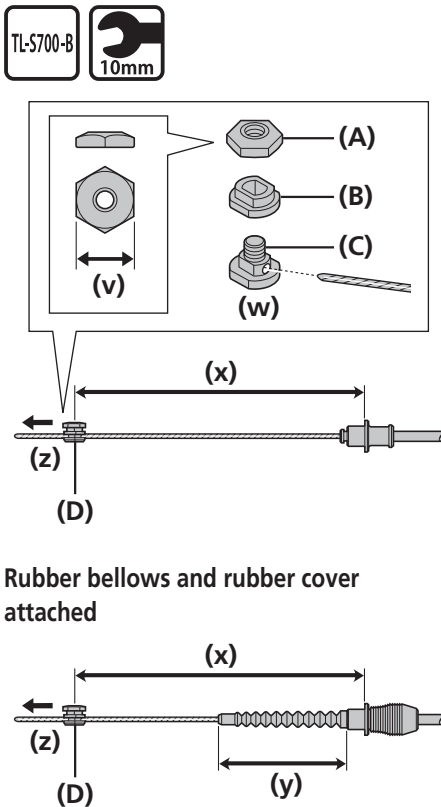

After checking that the end of the outer casing is securely set in the cable adjustment barrel of the shifting lever, attach the inner cable mounting bolt unit to the inner cable.

- (v) 10 mm
- (w) Pass the inner cable through the hole
- (x) 145 mm
- (y) 63 mm or less
- (z) Pull the inner cable when securing

- (A) Inner cable mounting nut (Black)
- (B) Inner cable mounting washer (Black)
- (C) Inner cable mounting bolt (Black)
- (D) Inner cable mounting bolt unit

Tightening torque



3.5 - 5.5 N·m

NOTICE

Use this inner mounting bolt unit as shown below.

Can be used: CJ-S700/CJ-C7000-8/
CJ-C7000-5

Cannot be used: CJ-NX10/CJ-NX40/CJ-8S20/
CJ-8S40



When installing the inner cable fixing bolt unit, use the setting tool TL-S700-B.

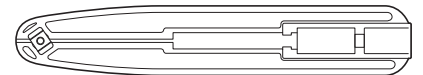

8

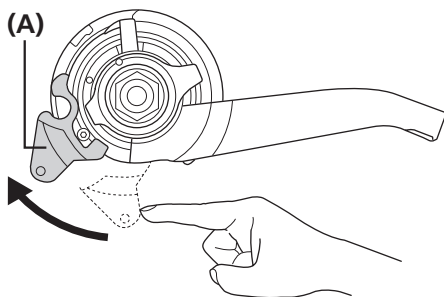

Turn the lever of the pulley clockwise. In the following steps 9 and 11, continue to work in this condition.

- (A) Pulley lever

▶▶ Installing to the cassette joint

9

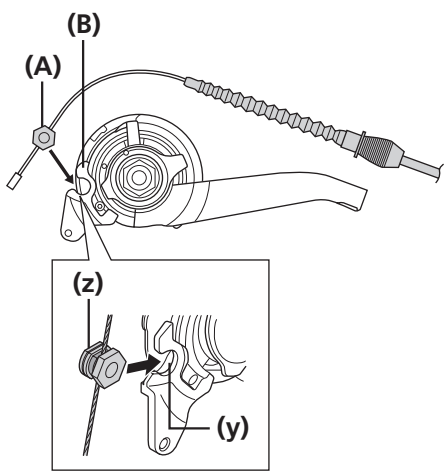

Bring the cable around to the cassette joint pulley, hold it so that the inner cable fixing nut is facing to the outside (toward the dropout), and then slide the flats part (y) of the inner cable fixing washer into the gap (z) in the pulley.

-
- (A) Inner cable fixing nut
 - (B) Pulley
-

10

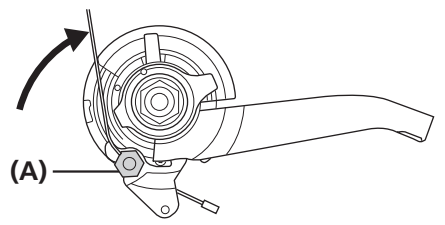

Turn the cable 60° counterclockwise and attach it to the hook.

-
- (A) Hook
-

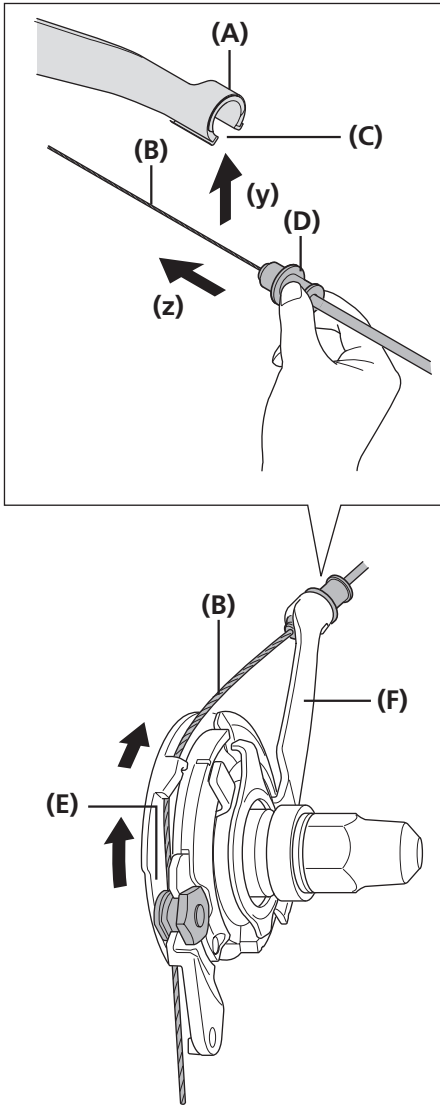

Set the inner cable in the pulley as shown in the illustration, insert the inner cable into the slit in the cassette joint bracket (y), and then securely set the outer casing holder unit into the outer casing holder of the cassette joint (z).

- (A) Outer casing holder
- (B) Inner cable
- (C) Slit
- (D) Outer casing holder unit
- (E) Pulley
- (F) Bracket

NOTICE

Check that the inner cable is correctly seated inside the pulley guide.

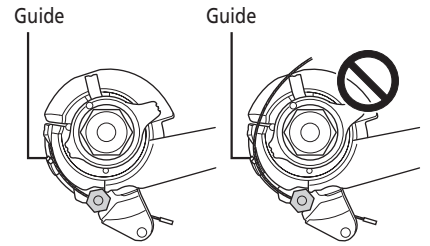

Rubber bellows and rubber cover attached

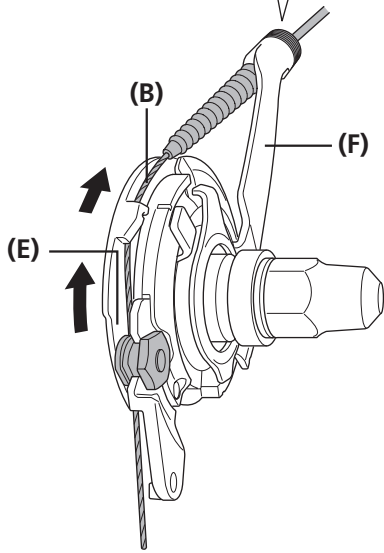
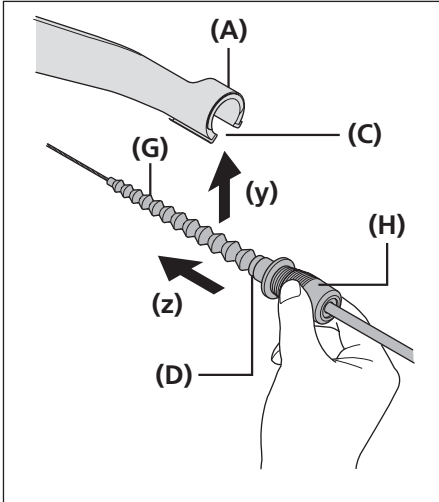

Set the inner cable in the pulley as shown in the illustration and, while holding the rubber cover, insert the rubber bellows of the inner cable into the slit in the cassette joint bracket (y) and securely set the outer casing holder unit into the outer casing holder of the cassette joint (z). Be careful not to damage the rubber bellows at this time.

- (A) Outer casing holder
- (B) Inner cable
- (C) Slit
- (D) Outer casing holder unit
- (E) Pulley
- (F) Bracket
- (G) Rubber bellows
- (H) Rubber cover

NOTICE

Check that the inner cable is correctly seated inside the pulley guide.

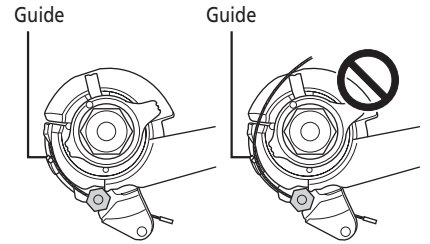

ADJUSTMENT

ADJUSTMENT

■ Adjusting the cassette joint

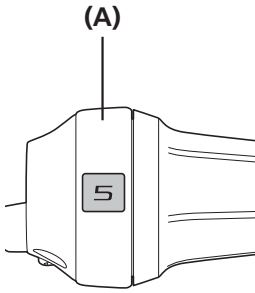
1		<p>Set SL-C7000-5 to 5.</p>
---	---	-----------------------------

(A) REVOSHIFT lever

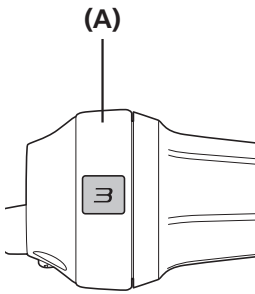
2		<p>Set SL-C7000-5 to 3.</p>
---	--	-----------------------------

(A) REVOSHIFT lever

NOTICE

When setting, do so gradually and with minimal force so as to avoid over-shifting. If you over-shift, the setting line will not return to the proper position, and the setting lines may not be aligned at the correct position. (Refer to procedure 3)

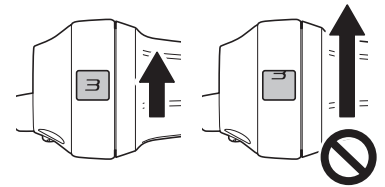

▶▶ Adjusting the cassette joint

3

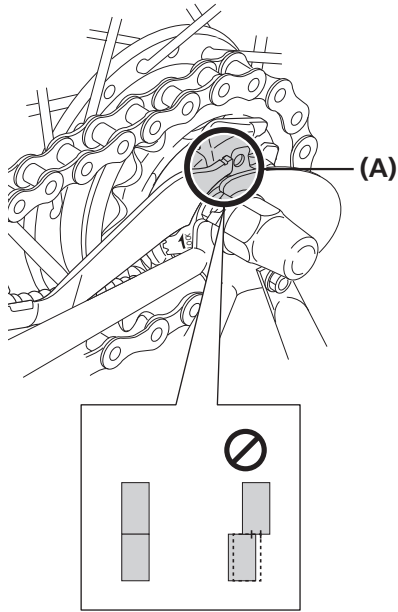

Check that the yellow setting lines on the cassette joint bracket and pulley are aligned with each other.

(A) Yellow setting lines

NOTICE

If the overlapping area falls short of two thirds of each setting line, the gears may not be properly engaged during pedaling, resulting in abnormal noise or free spinning of the pedals.

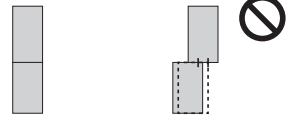

 **TECH TIPS**

The yellow setting lines on the cassette joint are located in two places. Use the one that is easiest to see.

When the bicycle is upright

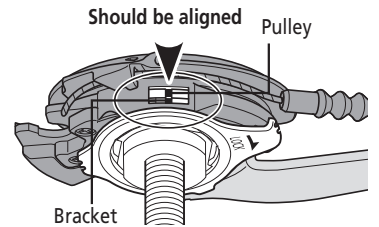

When the bicycle is upside down

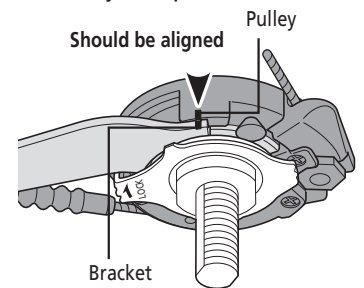

▶▶ Adjusting the cassette joint

If the yellow setting lines are not aligned

4

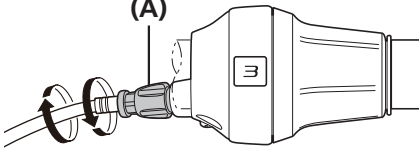

Turn the cable adjustment barrel of the REVOSHIFT lever to align the setting lines.

Move the REVOSHIFT lever once more from 3 to 5 and then back to 3, and then re-check to be sure that the yellow setting lines are aligned.

(A) Cable adjustment barrel

5

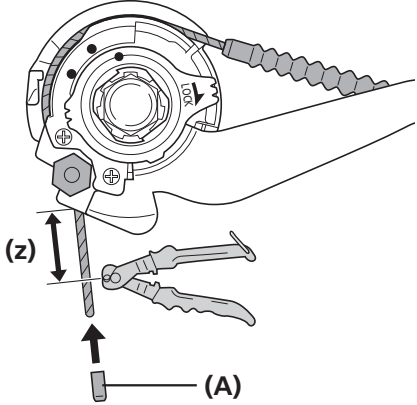

After adjusting the cassette joint, cut off the excess length of inner cable.

Next, install the inner end cap.

(z) 15 - 20 mm

(A) Inner end cap

MAINTENANCE

MAINTENANCE

■ Disconnecting the shifting cable when removing the rear wheel from the frame

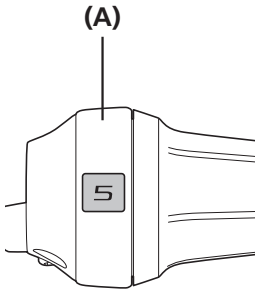
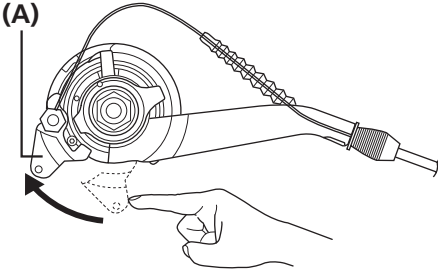
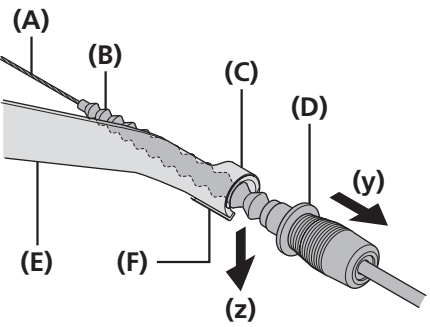
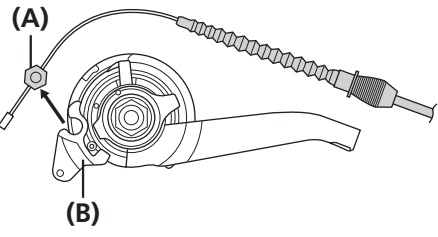
<p>1</p>		<p>Set SL-C7000-5 to 5.</p>	<p>(A) REVOSHIFT lever</p>
<p>2</p>		<p>Press the lever of the pulley clockwise to loosen the inner cable. In the following steps 3 and 4, continue to work in this condition.</p>	<p>(A) Pulley lever</p>
<p>3</p>		<p>Remove the outer casing holder unit from the outer casing holder of the cassette joint (y). Remove the inner cable from the slit in the bracket (z). Be careful not to damage the rubber bellows at this time (if rubber bellows are attached).</p>	<p>(A) Inner cable (B) Rubber bellows (C) Outer casing holder (D) Outer casing holder unit (E) Bracket (F) Slit</p>
<p>4</p>		<p>Remove the inner cable fixing bolt unit from the cassette joint pulley.</p>	<p>(A) Inner cable fixing bolt unit (B) Cassette joint pulley</p>
<p>NOTICE</p> <p>If reinstalling the cable, refer to steps 9 to 12 in "Cassette joint end".</p>			
<p>5</p>	<p>Detach the wheel.</p>		

■ Replacing the inner cable

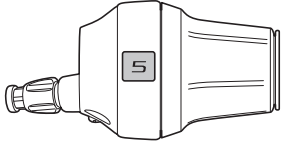
1		Set SL-C7000-5 to 5.
----------	---	----------------------

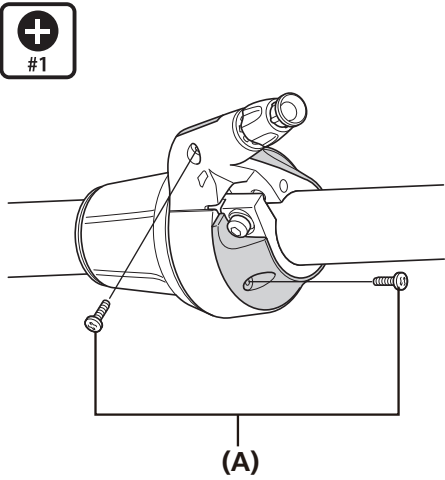
2	 (A)	Loosen the cover fixing screw.
----------	--	--------------------------------

(A) Cover fixing screw

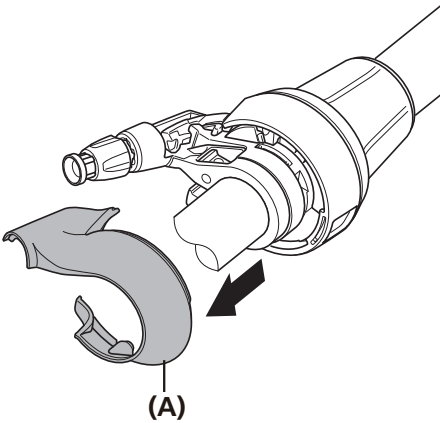
3	 (A)	Remove the cover.
----------	--	-------------------

(A) Cover

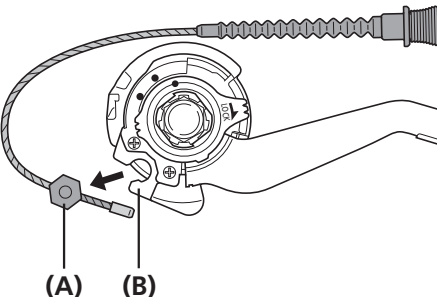
4	 (A) (B)	Remove the inner cable mounting bolt unit from the cassette joint pulley.
----------	--	---

(A) Inner cable mounting bolt unit
(B) Cassette joint pulley

▶ Replacing the inner cable

5

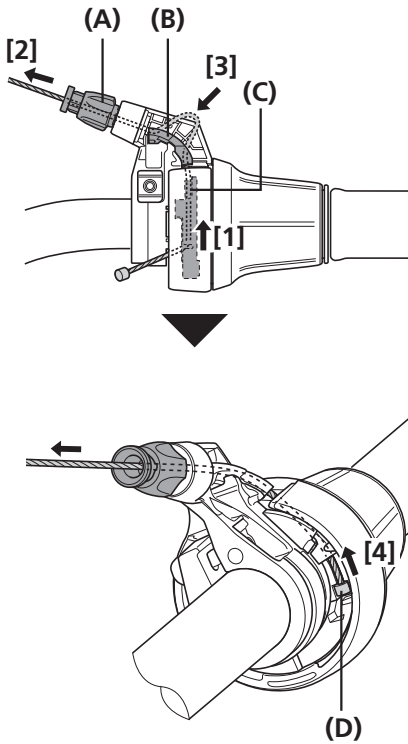

Pass the inner cable from the hole in the winder unit through the hole in the cable adjustment barrel.

Next, insert the inner cable into the groove of the cable guide.

Next, pull the inner cable so that the inner cable drum fits into the recess in the winder unit.

- (A) Hole in cable adjustment barrel
- (B) Groove of cable guide
- (C) Hole in winder unit
- (D) Recess in winder unit

6

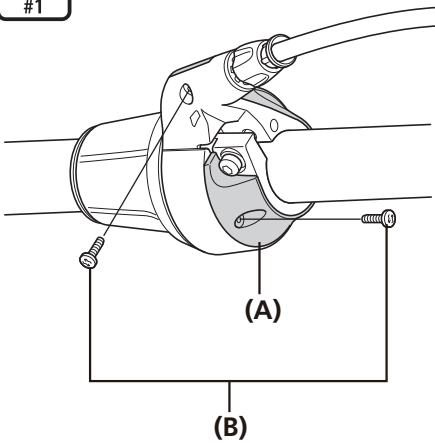

Replace the cover and tighten the cover fixing screws.

- (A) Cover
- (B) Cover fixing screw

Tightening torque



0.1 - 0.25 N·m

■ Oil maintenance of the internal assembly

To maintain the product in good working order, it is recommended to have the place of purchase or a distributor carry out maintenance such as lubrication of the internal parts about once a year from the first time of use (once every 2,000 km if the bicycle is used very frequently). If the bicycle is used under harsh conditions, more frequent maintenance is required. Also, for carrying out maintenance, the use of SHIMANO internal geared hub grease or a lubrication kit is recommended. If SHIMANO grease or a SHIMANO lubrication kit is not used, problems such as a malfunction in gear shifting may occur.

(A) WB maintenance oil set
(Y00298010)



(A)

1



Fill the container with maintenance oil to a height of 95 mm.

(z) 95 mm

2



Immerse the internal unit in the oil from the left side until the oil reaches up to ring gear unit 1, as shown in the illustration.

(z) Ring gear unit 1

3



Keep the internal unit immersed for approximately 90 seconds.

Oil maintenance of the internal assembly

4



Remove the internal unit from the oil.

5



Let excess oil drain off for approximately 60 seconds.

6



Reassemble the hub.

SHIMANO

SHIMANO NORTH AMERICA BICYCLE, INC.

One Holland, Irvine, California 92618, U.S.A. Phone: +1-949-951-5003

SHIMANO EUROPE B.V.

High Tech Campus 92, 5656 AG Eindhoven, The Netherlands Phone: +31-402-612222

SHIMANO INC.

3-77 Oimatsu-cho, Sakai-ku, Sakai City, Osaka 590-8577, Japan

Please note: specifications are subject to change for improvement without notice. (English)

© Apr. 2020 by SHIMANO INC. ITP